

# CONCENTRICITY GAGES

QUICK-POSITIONING, SUITABLE FOR MASS MEASUREMENT

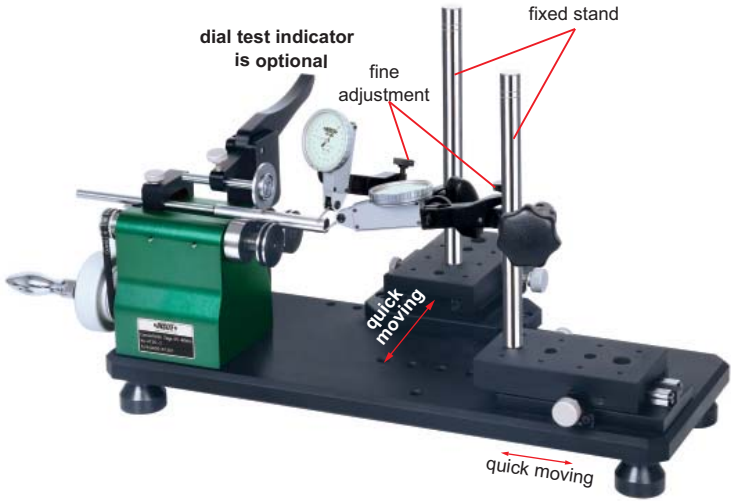

4726-2

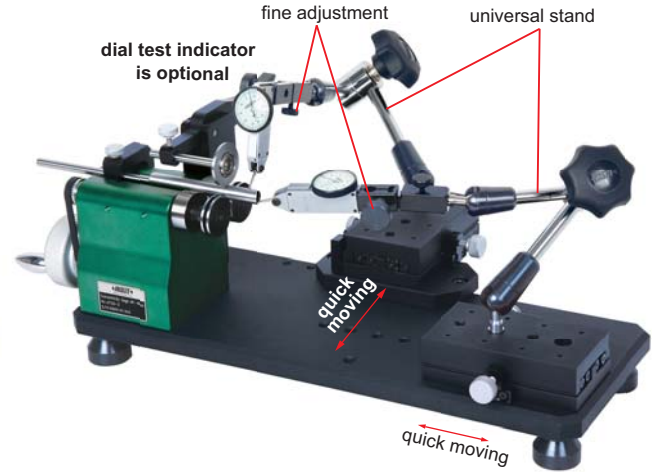

4726-21

- With ball bearing, high stability, long working life
- Accuracy: 2µm
- Optional accessory: dial test indicator

to ensure the accuracy 2µm, the distance between measuring point and roller should be <30mm

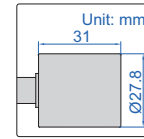
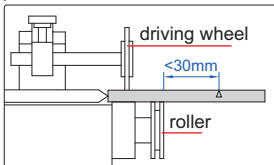

4726-1/11

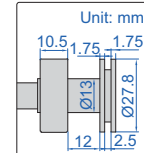

4726-2/21

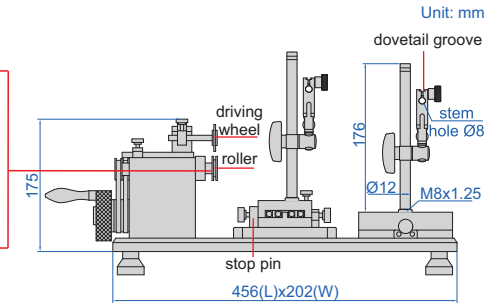

Code	Applicable diameter	Remark
4726-1	Ø4-40mm	fixed stand, high accuracy, inconvenient operation
4726-2	Ø2-40mm	fixed stand, high accuracy, inconvenient operation
4726-11	Ø4-40mm	universal stand, low accuracy, convenient operation
4726-21	Ø2-40mm	universal stand, low accuracy, convenient operation